

# Model 513AC

Mass Flow Meter

aerospace  
climate control  
electromechanical  
filtration  
fluid & gas handling  
hydraulics  
pneumatics  
process control  
sealing & shielding

Porter Model 513AC Series II Mass Flow Meter is designed for precise measurement of virtually all conventional process gases. The 513AC consists of a thermal mass flow sensor, and microprocessor based circuitry with signal and fieldbus conversion. The mass flow rate is provided as analog signal or digitally via RS232 or various fieldbus options. Each unit is specifically sized and calibrated depending on the type of gas and the process conditions of the application.



## Product Features:

- Full Scale Flow Ranges from 200 l/min to 1670 l/min
- Operating Pressures up to 1450 PSIG
- High accuracy and repeatability
- Storage of max. 8 calibration curves
- User configurable control characteristics
- Flow Parameter Adjust functionality up to 150 PSIG
- Effective Rangeability <180:1
- Analog or digital: RS232, DeviceNet™, ProfibusDP®, Modbus-RTU

# 500/600 Series II Flowmeter Products

## Thermal Mass Flow Measuring Principle

The Mass Flow Sensing System consists of a stainless steel capillary tube with two precision heater and temperature sensing elements wound around the outside of the tube. As gas flows through the capillary tube, heat is displaced to the downstream temperature sensor creating a differential between the two sensors. The difference is directly proportional to mass flow through the tube. In the main flow channel, a patented laminar flow element package creates a restriction that forces a fixed percentage of the total flow through the sensor for temperature differential detection.

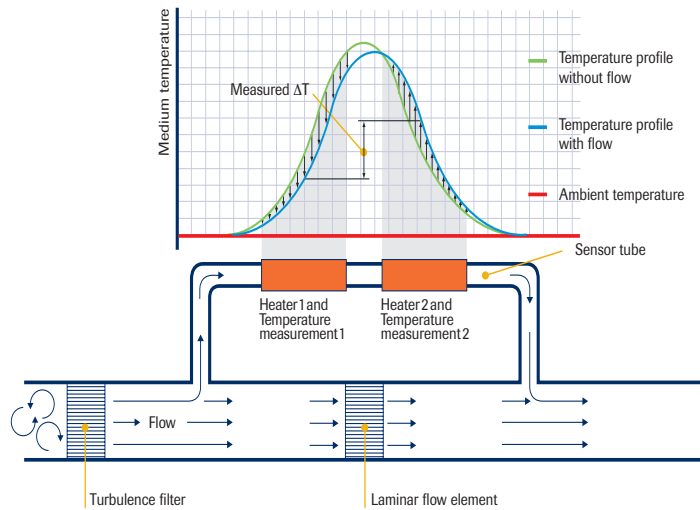

$$\Delta T = k \cdot C_p \cdot \dot{Q}_m \quad \Delta T = T_2 - T_1 \text{ in Kelvin} \quad C_p = \text{specific heat} \quad \dot{Q}_m = \text{mass flow}$$

## State of the Art Digital Design

Porter's Series II Mass Flow products are equipped with a microprocessor based digital pc-board offering high accuracy, excellent temperature stability and fast MFC response time. The basic digital pc-board contains all of the general functions needed for measurement and control. RS232 communication and analog I/O are included. An optional integrated communication interface board provides DeviceNet™, Profibus-DP® or Modbus-RTU.

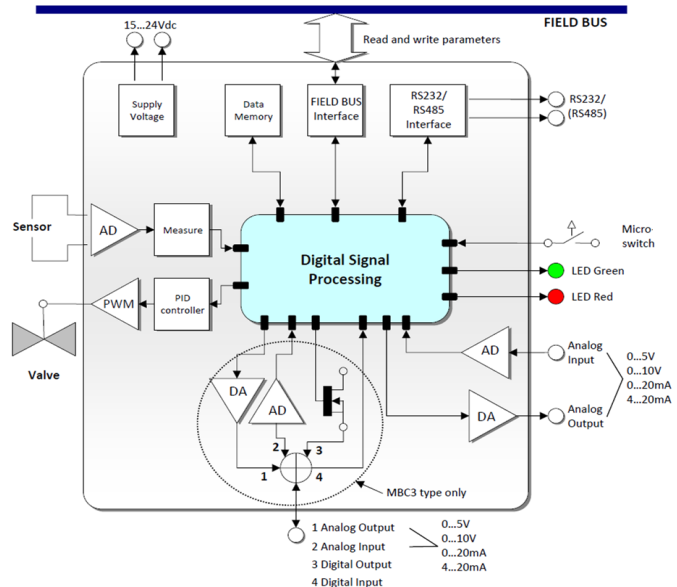

## Models and Flow Ranges

Model	Minimum	Nominal	Maximum
513AC - U	4 to 200 l/min	4 to 500 l/min	4 to 750 l/min
513AC - V	8 to 400 l/min	8 to 1000 l/min	8 to 1670 l/min

All flow ranges are at standard conditions of 14.7 PSIG and 70°F (21.1°C)

# Specifications

## Measurement / Control System

<b>Accuracy (incl. linearity) (based on actual calibration)</b>	Standard: $\pm 0.5\%$ Reading plus $\pm 0.1\%$ Full Scale ( $\pm 1\%$ Full Scale for ranges 3-5 ml/min; $\pm 2\%$ Full Scale for ranges $< 3$ ml/min)
<b>Turndown</b>	1 : 50 (in digital mode up to 1 : 187.5)
<b>Repeatability</b>	$< 0.2\%$ Reading
<b>Settling Time (Controller)</b>	Standard: 1-2 seconds
<b>Control Stability</b>	$< \pm 0.1\%$ Full Scale (typical for 1 l/min N <sub>2</sub> )
<b>Operating Temperature</b>	-10 to +70°C
<b>Temperature Sensitivity</b>	Zero: $< 0.05\%$ Full Scale/°C; span: $< 0.05\%$ Reading/°C
<b>Pressure Sensitivity</b>	0.1%/ATM typical N <sub>2</sub> ; 0.01%/ATM typical H <sub>2</sub>
<b>Leak Integrity, outboard</b>	Tested $< 2 \times 10^{-9}$ mbar l/s He
<b>Attitude Sensitivity</b>	Max. error at 90° off horizontal 0.2% at 1 ATM, typical N <sub>2</sub>
<b>Warm-Up Time</b>	30 min. for optimum accuracy 2 min. for accuracy $\pm 2\%$ Full Scale

## Mechanical Parts

<b>Material (wetted parts)</b>	Stainless steel 316L or equivalent
<b>Surface Quality (wetted parts)</b>	Ra= 0.8µm typical
<b>Process Connections</b>	Compression or face seal fittings
<b>Seals</b>	Standard: Viton Options: EPDM, Kalrez (FFKM)
<b>Ingress Protection (housing)</b>	IP40

## Electrical Properties

<b>Power Supply</b>	+15-24 Vdc
<b>Power Consumption</b>	Meter: 70 mA; Controller: max. 320 mA; Add 50 mA for Profibus, if applicable
<b>Analog Output/Command</b>	0-5 (10) Vdc or 0 (4)-20 mA - specify - (Sourcing output)
<b>Digital Communication</b>	Standard: RS232 Options: Profibus-DP®, DeviceNet™, EtherCAT®, Modbus

## Electrical Connection

<b>Analog/RS232</b>	9-pin D-connector (male)
<b>Profibus-DP®</b>	Bus: 9-pin D-connector (female) Power: 9-pin D-connector (male)
<b>DeviceNet™</b>	5-pin M12-connector (male)
<b>EtherCAT®</b>	2 x RJ45 modular jack (in/out)
<b>Modbus-RTU/FLOW-BUS</b>	RJ45 modular jack

*Technical specifications and dimensions subject to change without notice.*

# Dimensions

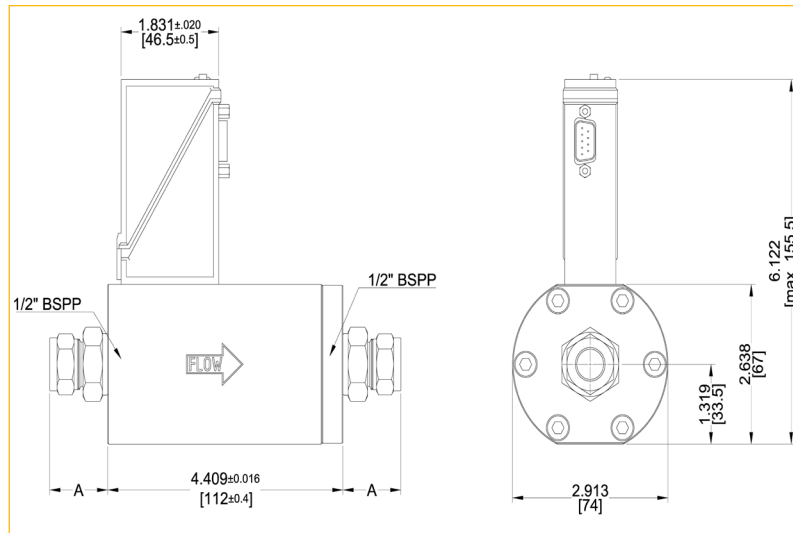

Bracket = Millimeters

Compression		1/2" BSPP
		Size A
Fitting 10 mm OD		1.220 (31.0)
Fitting 12 mm OD		1.319 (33.5)
Fitting 20 mm OD		1.437 (36.5)
Fitting 25 mm OD		1.654 (42.0)
Fitting 3/8" OD		1.209 (30.7)
Fitting 1/2" OD		1.319 (33.5)
Fitting 3/4" OD		1.370 (34.8)

Face-Seal Male		1/2" BSPP
		A
Fitting 1/4" inlet		0.913 (23.2)

(Millimeters)

# Ordering Information

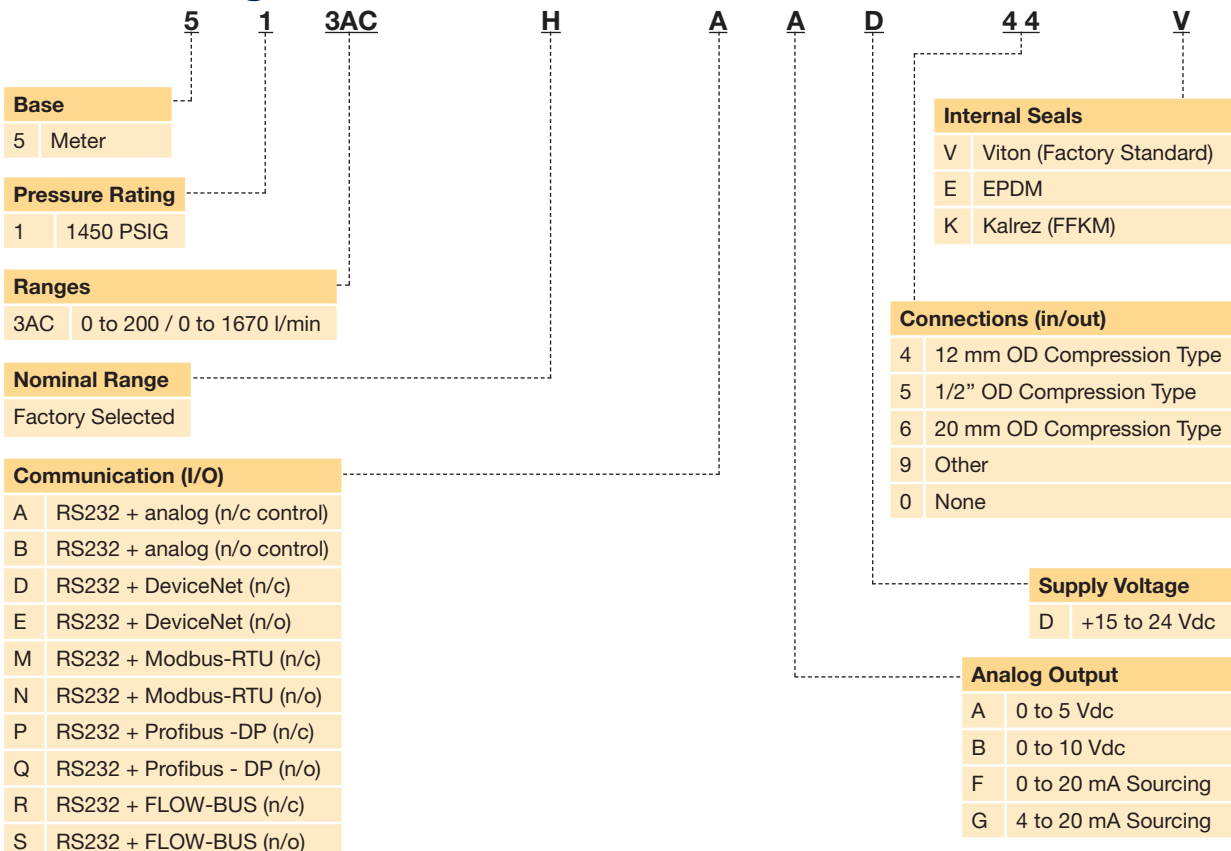

# Hook-up Diagram for Analog or RS232 Communication

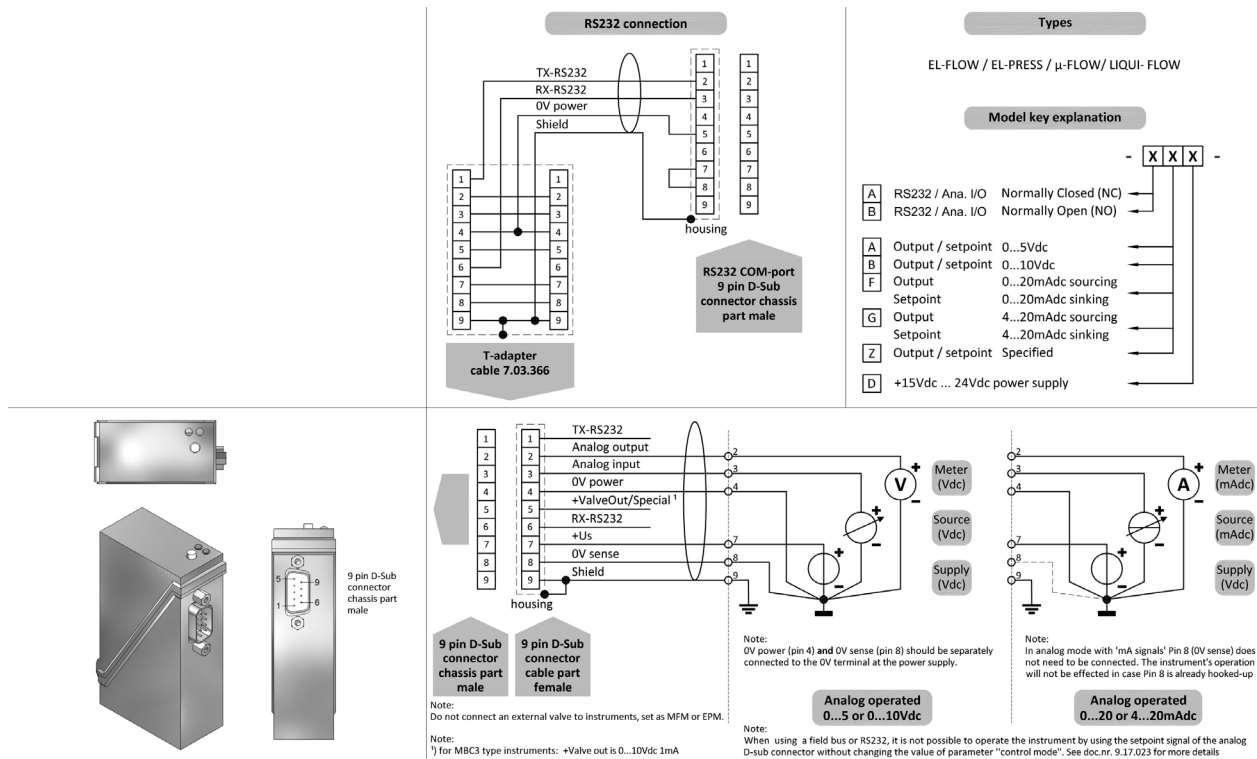

## WARNING – USER RESPONSIBILITY

**FAILURE OR IMPROPER SELECTION OR IMPROPER USE OF THE PRODUCTS DESCRIBED HEREIN OR RELATED ITEMS CAN CAUSE DEATH, PERSONAL INJURY AND PROPERTY DAMAGE.**

This document and other information from Parker-Hannifin Corporation, its subsidiaries and authorized distributors provide product or system options for further investigation by users having technical expertise.

The user, through its own analysis and testing, is solely responsible for making the final selection of the system and components and assuring that all performance, endurance, maintenance, safety and warning requirements of the application are met. The user must analyze all aspects of the application, follow applicable industry standards, and follow the information concerning the product in the current product catalog and in any other materials provided from Parker or its subsidiaries or authorized distributors.

To the extent that Parker or its subsidiaries or authorized distributors provide component or system options based upon data or specifications provided by the user, the user is responsible for determining that such data and specifications are suitable and sufficient for all applications and reasonably foreseeable uses of the components or systems.

## Offer of Sale

The items described in this document are hereby offered for sale by Parker-Hannifin Corporation, its subsidiaries or its authorized distributors. This offer and its acceptance are governed by the provisions stated in the detailed "Offer of Sale" elsewhere in this document or available at [www.parker.com/offerofsale](http://www.parker.com/offerofsale).

WS-0027 Rev. B 08/13

Parker Hannifin Corporation  
**Porter Instrument Division**  
 245 Township Line Road  
 Hatfield, PA 19440

phone 215 723 4000  
 fax 215 723 2199  
 industrial@parker.com

[www.parker.com/porter](http://www.parker.com/porter)



ENGINEERING YOUR SUCCESS.